

Vertical Platform Lifts



Whether access is needed for indoor or outdoor applications, our vertical platform lifts are a safe, economical, and space effective way to overcome architectural barriers.

National Wheel-O-Vator is capable of customizing the vertical platform lift while maintaining the durability and dependability individuals have come to associate with our lifts. WWW.WHEELOVATOR.COM

National Wheel-O-Vator

A Division of ThyssenKrupp Access



Model BC - Acme screw drive
 Model HBC - Hydraulic drive



BC with runway enclosure built by others

The BC and HBC models are manufactured as an unenclosed lift. This unit is often installed within a vertical runway enclosure built by others. In some commercial settings, where the travel distance is less than 5 feet, a BC or HBC may be installed unenclosed. Because of its versatility, this model can overcome architectural barriers in a variety of different settings. Common applications include: churches, libraries, restaurants, and schools. Each vertical platform lift is designed to be able to conform to the requirements in ANSI A18.1 when properly equipped and installed. Check with local authorities for code regulations.



Flush mounted steel door



Unenclosed BC



Fired rated steel door

National Wheel-O-Vator can supply a wide variety of flush mounted doors/gates to finish the job. Typical doors are flush mounted steel units ranging in height from 42" to 80". We also produce non-fire rated wood doors that come finished or unfinished. If required, fire rated steel doors can be supplied, which are primed in gray. Local codes and regulations will specify the type of door permitted in your area.

Our engineering experts can design a vertical platform lift to meet the needs of most building applications.



Non-fired rated wood door

Model CDE - Acme screw drive
Model HCDE - Hydraulic drive

14 42 00/NAT
Buyline 6071



CDE/HCDE models are manufactured with a steel runway enclosure to eliminate the need for a separate enclosure to be built on site. A structural steel framework is used on indoor enclosures, while an aluminum framework is used on outdoor units to minimize corrosion.



CDE 3-gate shown in the above two pictures.

Runway enclosures can be extended and roofs added to protect the user from inclement weather. In such cases, optional lighting and a ventilation system may be required.

Our 3-gate CDE is used to reduce the enclosure height, therefore; providing a cleaner "line of sight" for the user.

Model PCDE - Acme screw drive
Model HPCDE - Hydraulic drive

The PCDE and HPCDE models come equipped with a factory supplied enclosure with either clear or tinted acrylic panels. These attractive models allow light into the runway and permit the user to see outside the unit during operation.



Model PCDE utilizing the Low Profile Carriage

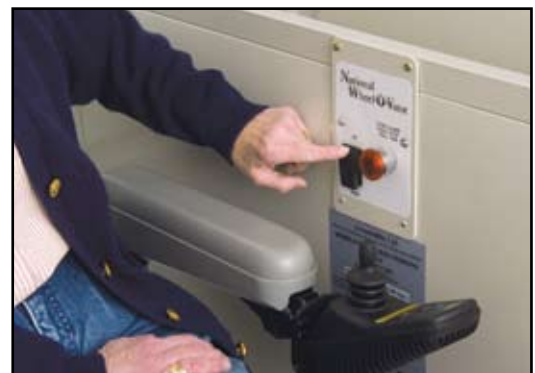

A main control panel is found on the side guard of each vertical lift. This panel consists of a constant pressure switch and an emergency stop button.

Options



FSV Package - The fastest screw driven vertical platform lift available in the market today. The FSV package allows for travel speeds up to 30 feet per minute on all of our Acme Screw Drive units, which means you get to your destination up to 3 times faster than other vertical platform lifts. Contact your local dealer for details.

Standby Power Package - An optional standby power package is available on all our screw and hydraulic drive vertical platform lifts. This package allows the unit to be raised or lowered under emergency battery power.

Extruded Aluminum Enclosure Package - For those seeking a vertical platform lift with a contemporary look and feel, an extruded aluminum enclosure package is available for our Model CDE and PCDE. This package includes aluminum side guards, complimented by a stainless steel grab rail and call/sends.



Architect White is the standard color for extruded aluminum



Our aluminum grab rail is a required option on all commercial lifts.



A stainless steel face plate with emergency platform lighting is available as an option. To make the unit more secure, an on/off keyed switch can be added on all operating panels.

Low Profile Carriage

We encourage all vertical platform lifts to be installed in a pit to provide the user an unobstructed entrance to the unit. However, many applications cannot be pitted and a lower level ramp is required. Ramps are typically 30" long.

Our "low profile carriage" option is available on enclosed vertical platform lifts. This feature reduces the lower landing height by approximately 50%. National Wheel-O-Vator's design reduces the ramp length to 16" in new construction and as short as 10" in existing construction. The low profile carriage decreases the total space required and greatly enhances user convenience.

Model WOV 355



The WOV355 is a vertical platform lift that looks like an elevator. This model has a 1:2 roped hydraulic drive and full height interior platform walls. A suspended style ceiling with florescent lighting is also provided to complete the enclosure. Similar to our other vertical models, the control panel buttons on the WOV 355 require constant pressure for the lift to raise and lower.



Drawings

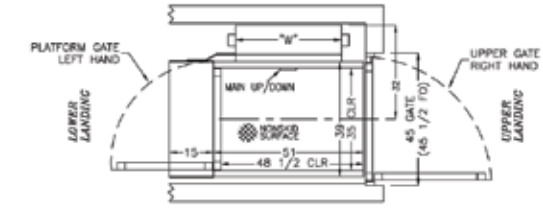

PLAN VIEW

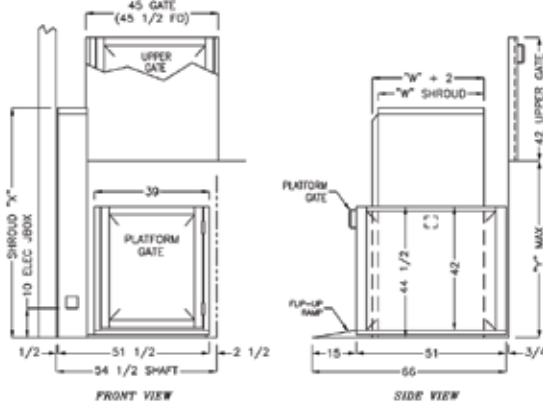

BC/HBC Model with Extruded Aluminum Side Guard

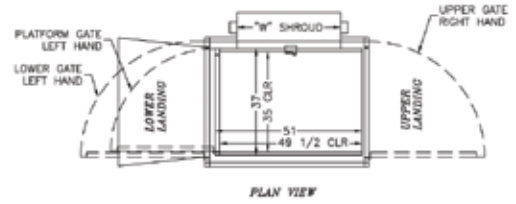

PLAN VIEW

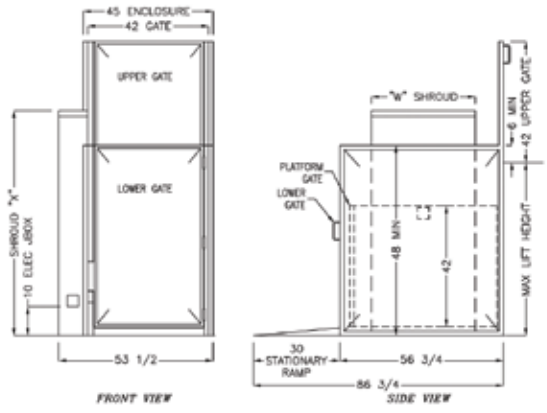

CDE/HCDE Model 3-Gate with Steel Side Guard

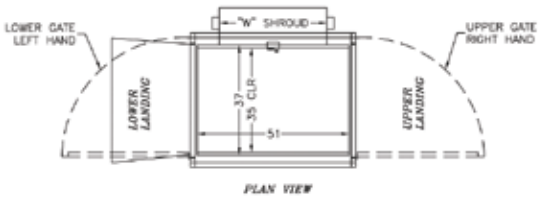

PLAN VIEW

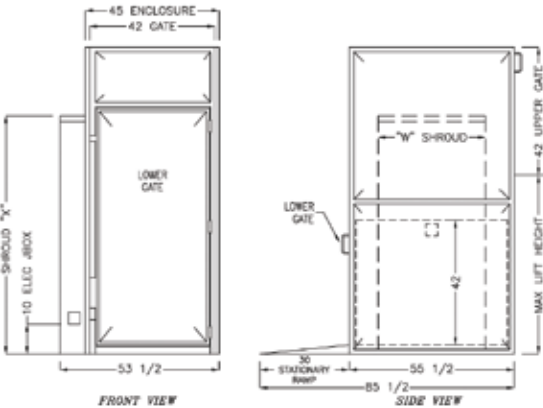

CDE/HCDE Model 2-Gate with Steel Side Guard

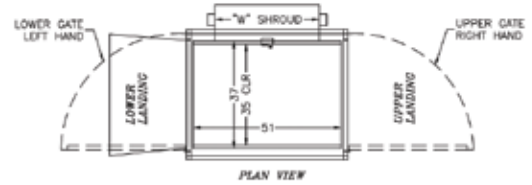

PLAN VIEW

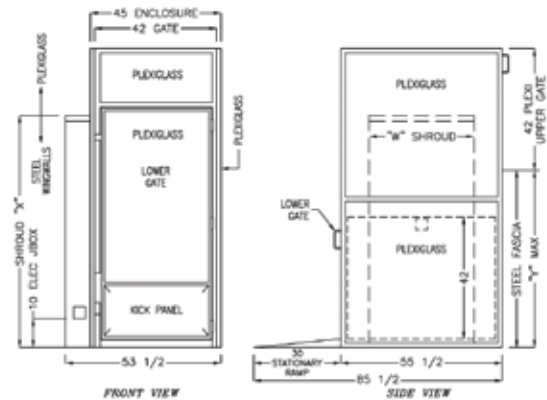

PCDE/HPCDE Model with Steel Side Guard

Please note: All units are shown with equipment dimensions only and are subject to change. Changes in platform size and configuration will change dimensions. Additional room for running clearances will also be required. The drawing dimensions will increase with the FSV (Fast Speed Vertical) package.

MODELS RE*, BC, CDE, PCDE		ACME SCREW DRIVE			Shroud Dimension "W" All Units 36 1/4" (0.92m)					
MODEL	24(RE ONLY)	42	60	72	96	108	120	144	156	168
MAX.LIFT HGT	27"	45"	63"	75"	99"	111"	123"	147"	159"	171"
SHROUD "X"	45"	63"	81"	93"	118"	130"	142"	171"	183"	195"
MODELS HBC, HCDE,HPCDE1:2 CHAIN HYDRAULIC DRIVE		Shroud Dimension "W" All Units 41 3/8" (1.05m)								
MODEL	24(RE ONLY)	42	60	72	96	108	120	144	156	168
MAX.LIFT HGT	NA	45"	63"	75"	99"	111"	123"	147"	159"	171"
SHROUD "X"	NA	69"	87"	99"	123"	135"	147"	171"	183"	195"
REFERENCE: *RE AVAILABLE IN 24, 42, 60, 72 MODELS ONLY - LIFT HEIGHT MUST INCLUDE PIT DEPTH, WHEN PITTED										

Below is a general guide specification containing performance and descriptive requirements which apply to a variety of standard and custom National Wheel-O-Vator products.

PART 1 - GENERAL

1.1 REFERENCES

- A. The lift shall be designed and tested in accordance with ICC/ANSI A117.1, NEC and ASME A18.1
- B. All designs, clearances, construction, workmanship and installation shall be in accordance with the requirements and codes adopted by the authority having jurisdiction. The platform lift shall be subject to local, city and state approval prior to and following installation.

1.2 SYSTEM DESCRIPTION

- A. The product described herein, manufactured by National Wheel-O-Vator, a division of ThyssenKrupp Access, is a vertical platform lift consisting of a machine tower with a lifting platform, selected and dimensioned to provide adequate lifting height to suit the individual building requirements. The lift can be used either indoors or outdoors to vertically transport a wheelchair user or mobility impaired person over a barrier creating access to or within a building.

B. Performance

- 1. Rated Load: 750 pound capacity
- 2. Travel Speed: Acme Screw-9 fpm
FSV Acme Screw-30 fpm
Hydraulic-20 fpm
- 3. Lifting Height: _____(14' max)

1.3 QUALITY ASSURANCE

- A. Manufacturer: A company with not less than fifteen years of experience in the design and fabrication of vertical platform lifts.
- B. Technical services: Manufacturer and dealer shall work with architects, engineers and contractors to adapt the platform lift product to the design and structural requirements of the building, site, and code requirements.

1.4 WARRANTY

- A. Unit shall have a four (4) year limited parts warranty on the basic unit, including all electrical and drive system components.

PARTS 2 - PRODUCTS

2.1 MANUFACTURER

- A. The unit shall be manufactured by National Wheel-O-Vator, a division of ThyssenKrupp Access as distributed by

2.2 FABRICATION

A. Drive Systems:

- 1. Acme Screw: Motor minimum of 3/4 HP, instant reverse, 1750 RPM, 115 VAC, single phase (220 volt optional). Back-up safety nut and auto-lubrication system.
- 2. Hydraulic: 24 VDC 1 1/2 HP. Drive = 1:2 leaf chain hydraulic with type "A" slack chain safety device.

- B. Platform shall be constructed of 12 gauge minimum zinc clad steel. If unit is not installed in a 3" pit, a stationary ramp shall be provided that extends under the lower landing gate/door.

- C. Platform side panels must be 42" high (36" residential). Side panel framework shall be a minimum of 1"x 1 1/2"x .065 steel tubing for indoor units and 1x1 1/2x .125 aluminum tubing for outdoor unit. Solid infill panels shall be a minimum of 18 gauge zinc clad steel.

- D. The mainframe support tubings shall be a combination of square and rectangular steel tubing with a minimum .120 wall thickness.
- E. Carriage arms shall be a minimum of 1"x2" steel flat bar along with 1/2" thick steel flat bar uprights. Cam rollers shall be used for axial carriage guidance and wear pads used for horizontal stability. On Hydraulic units, cam rollers shall be supported by a minimum 6.25#/ft. "T" rail with tongue and groove ends mated at the split sections of the machine tower.
- F. Upper and lower limit switches
- G. Upper final limit switch
- H. Secondary safety nut (Acme Screw) or Slack Chain Device (Hydraulic)
- I. 24V low voltage controls
- J. Grounded electrical system
- K. Non-skid platform and access ramp
- L. Platform safety pan or runway enclosure
- M. Emergency stop button
- N. Top and bottom landing gates/doors provided with combination mechanical lock with positive opening electrical contacts. (Local code may vary)
- O. Grab rail
- P. Machine Tower (Shroud)

- 1. Acme Screw: Machine tower structural side plates shall be of 12 gauge steel and front and back covers shall be 18 gauge zinc clad steel minimum.
- 2. Hydraulic: The removable machine tower sides shall be of 16 gauge zinc clad steel and front and back covers shall be 18 gauge zinc clad steel minimum.

PART 3 - EXECUTION

3.1 ACCEPTABLE INSTALLERS

- A. Subcontractor Qualifications: A company that is listed as an authorized National Wheel-O-Vator dealer.
- B. Electrical devices, services and final connections shall be by a qualified electrician.

3.2 INSTALLATION

- A. Unit shall be installed and operated in accordance with the ICC/ANSI A117.1, NEC and ASME A18.1 Guidelines.
- B. Coordinate work with general contractor.
- C. Leave standard electrical connection drawings with electrical contractor to make final electrical connection.
- D. The installation of the vertical platform lift shall be made in accordance with the approved plans and specifications and the manufacturers installation instructions.

3.3 FIELD QUALITY CONTROL

- A. Load the vertical lift to rated capacity and test for several cycles to insure proper operation. No mechanical failures shall occur and no wear that would affect the reliability of the unit shall be detected.

* Note: Specifications are subject to change.

Color Selections

All colors are textured.

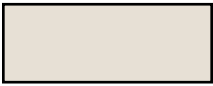

Pearl White
Standard



Architect White
Optional



Lentan
Optional



Brown
Optional



Gray
Optional



Black
Optional

Model RE - Acme screw drive



The RE model unit is designed with the homeowner in mind. This lift is similar to the BC model; however, the platform side guards and gates are only 36" tall, thus making the unit "for residential use only".

The RE model is an affordable alternative to lengthy, costly, and unsightly ramps. The lifting heights of 24", 42", 60", and 72" will satisfy most applications. For heights greater than 72", a BC model may be used.



Model BC Portable Vertical Platform Lift



The portable vertical platform lift can be an ideal solution for access to a stage or platform. Since the unit is equipped with wheels, it can be moved when access to the stage is not necessary, and the room needs to be used for other functions. In some cases, a variance may be required.

Other Products

In addition to offering a complete line of vertical platform lifts, National Wheel-O-Vator also provides top of the line stairway chair lifts, residential elevators and commercial LU/LA elevators.

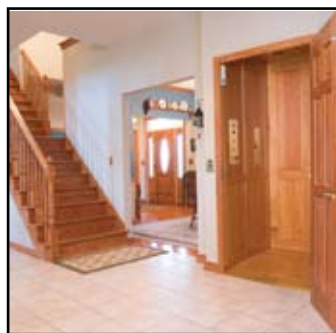
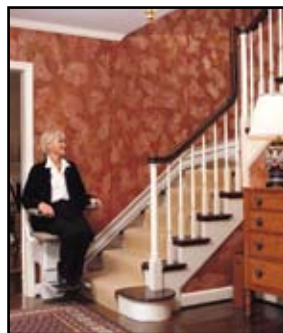

National Wheel-O-Vator
A Division of ThyssenKrupp Access
 509 W. Front Street
 Roanoke, IL 61561
 Ph: 888-353-8898 Fax: 309-923-5091

Email: vertical@wheelovator.com
 Web site: www.wheelovator.com

Your Authorized Dealer is: