

Total Folding Lift

# PRODUCT	DESCRIPTION	MARKET
#82101041	Folding floor lift - Junior	North America
#82101044	Folding floor lift - Junior	Australia
#82101048	Folding floor lift - Junior	Europe & United Kingdom

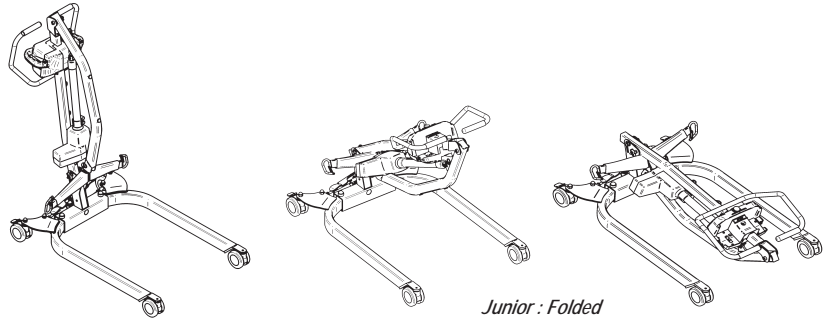

Junior : Folded

# Junior

Lifting capacity:  
350 lb / 159 kg / 25.04 st

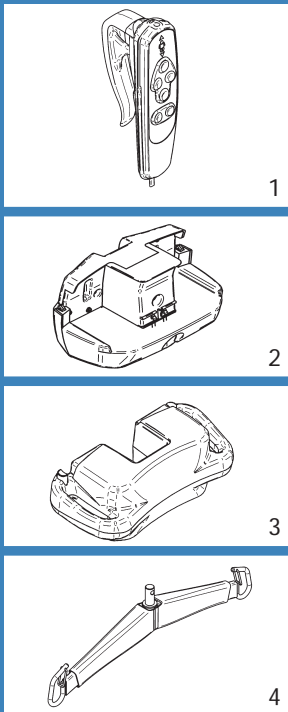

√ = Included / O = Optional

# PART	DESCRIPTION	#82101041	#82101044	#82101048
1 #700.13610	Hand Control	√	√	√
2 #700.16051	Wall charger - North America	O		
2 #700.16053	Wall charger - Europe			O
2 #700.16054	Wall charger - Australia		O	
2 #700.16055	Wall charger - United Kingdom			O
3 #700.16200	Battery Pack	√	√	√
4 #700.05496	Spreader bar	√	√	√

JUNIOR	CONTROL BOX WITH INTEGRATED CHARGER
#82101041	#700.16008.2
#82101044	#700.16008.2
#82101048	#700.16008.2

SUGGESTED SLINGS & STRETCHERS	Hammock & Hammock 6	Hygienic	Quick Fit	Band	Chest	Total transfer	Combi	Repositioning	Bariatric	Walking	Soft	Universal	Margue
	Slings											Stretchers	
	√	√	√				√	√					

(For more details, look into the Sling Section)

### FEATURES

Weight	39.6 kg / 87.12 lb / 6.24 st
Lifting capacity	159 kg / 350 lb / 25.04 st
Soft start & stop movement	

### SAFETY FEATURES

Dual controls	
Emergency Shut-Off	
Manual emergency lowering device	Slowly drop to the desired level

### TECHNICAL SPECIFICATIONS

Control box - CSA, UL & CE approved
-------------------------------------

### BATTERY SPECIFICATIONS

Rechargeable & removable battery pack	(2X) 12Vdc, 5Ah
Charger	Integrated, plug in lift
Battery capacity with load of 90 kg / 200 lb / 14.17 st	Up to 100 Lifts per charge
Low battery warning indicator	Visual
Charge input	90-240 Vac, 50-60 Hz, 27 VA
Charge indicator	Visual
Charging time	3-4 hours

### BASE

Material	Steel
Cab	Fire retardant plastic
Finish	Powder Coat Beige

### EXPLODED VIEW

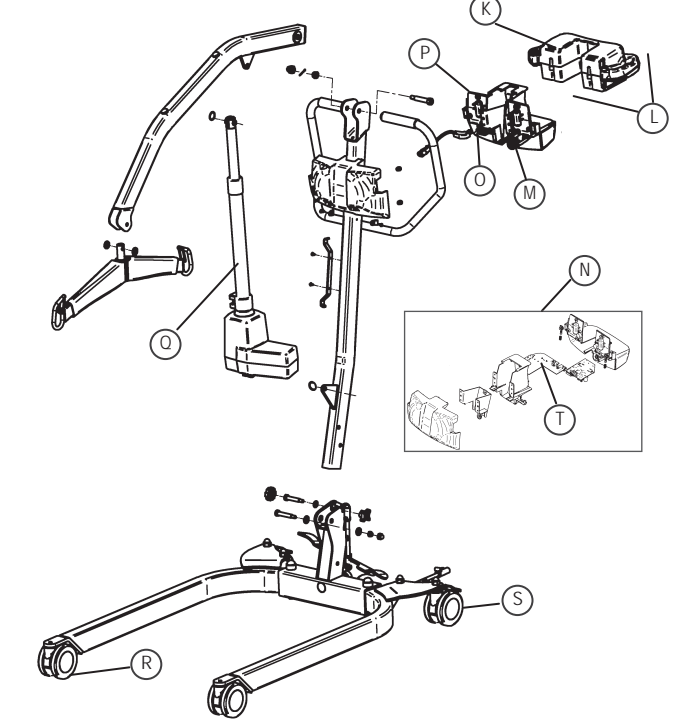

### DIMENSIONS

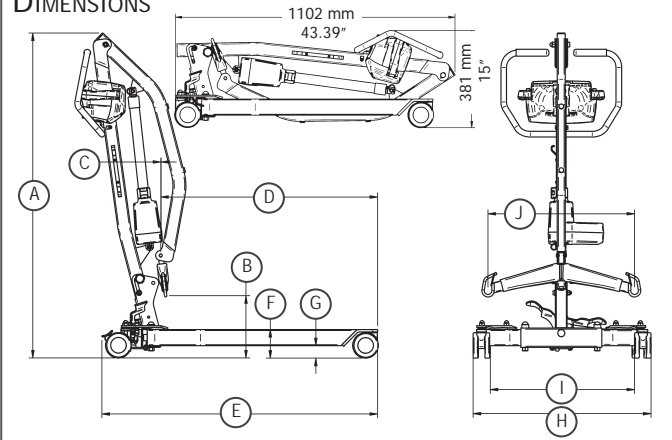

### DIMENSIONS

DESCRIPTION	HOISTING HEIGHT AT :			
	MIN		MAX	
	MM	IN	MM	IN
A Total lift height	1278	50.31	1771	69.72
B Hoisting height at connecting points	246	9.69	1618	63.7
C CSP Hoisting reach	3	0.12	452	17.8
D CSP from base end	851	33.5	400	15.75
	mm		in	
E Base total length	1082		42.6	
F Base height	112		4.4	
G Base floor clearance	48		1.9	
H External base width (legs closed)	693		27.3	
H External base width (legs open)	1111		43.7	
I Internal base width (legs closed)	565		22.2	
I Internal base width (legs open)	987		38.9	
J Connecting points distance	580		22.8	
Turning radius	945		37.2	
Minimum door requirement	660		26.0	

### COMMON SPARE PARTS

K	#403.10500 (X2)	Battery
L	#700.16200	Battery pack
M	#492.0045-5	Circuit board - Control box
N	#700.16051	Wall charger - North America
N	#700.16053	Wall charger - Europe
N	#700.16054	Wall charger - Australia
N	#700.16055	Wall charger - United Kingdom
O	#492.00031-4	Circuit board - Charger
P	#700.16008.2	Control box (with charger)
Q	#E6520	Actuator
R	#000.20430	Caster Front
S	#000.20435	Caster back
T	#492.00045-2	Circuit board - Wall charger