

This stretcher is specifically designed to transfer a person in a supine position. The sling is made from nylon/polyester material that is easy to manipulate and allows for air circulation. The frame can be assembled around the person once the sling has been installed, which makes the installation faster and easier. The buckles at the headrest and footrest offer flexibility to adjust the comfort level. Fits all BHM Medical lifts however, works best with BHM Medical ceiling lifts.

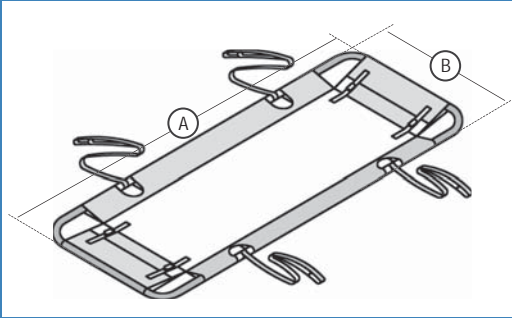

# PRODUCT	DESCRIPTION
#A3510	Universal Stretcher Sling
#A3500	Universal Stretcher Sling & Frame

FEATURES	
Warranty against defect	1 year - washable models*
Safe working load	272 kg / 600 lb / 42.86 st
Stainless steel frame	Easily assembled around the person by slipping frame parts into loops of sling. Frame is rust resistant so it can be submerged in water
Soft polyester net	Specially designed fabric is ultra-soft, long lasting and dries quickly. Fabric is easy to move, easy to install. Adjustable headrest and footrest
Machine washable	Easy to clean and care for

TECHNICAL SPECIFICATIONS	
Conforms to ISO 10535 & Marked CE	
*Conditional to normal use and maintenance according to appropriate labels, the sling must be used only with the appropriate BHM Medical Inc. lifting devices.	

Universal Stretcher

UNIVERSAL STRETCHER SLING & FRAME				
# PRODUCT	DESCRIPTION		DIMENSIONS	
			CM	IN
#A3510	Universal Stretcher Sling Capacity 272 kg - 600 lb max.	A	190	75
		B	74	29
#A3510	Universal Stretcher Sling & Frame Capacity 272 kg - 600 lb max.	A	190	75
		B	74	29

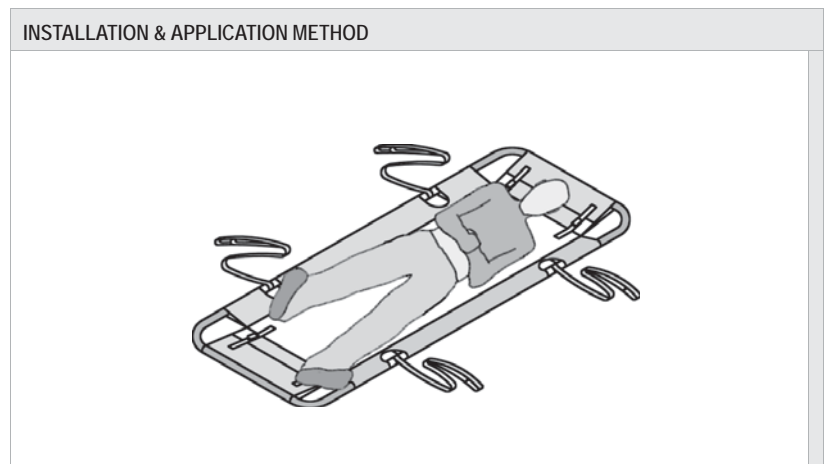

Refer to Sling Operating & Product Care Instructions Guide for complete application details.