

The morgue transfer device consists of the morgue spreader bar and body bands. The spreader bar is made of stainless steel and has multiple positioning points. The bar is attached to the lift replacing standard carry bar. The body bands are fluid resistant and can be easily cleaned.

The body bands also have multiple connection points ensuring secure transfer. Fits all BHM Medical lifts however, works best with BHM Medical ceiling lifts.

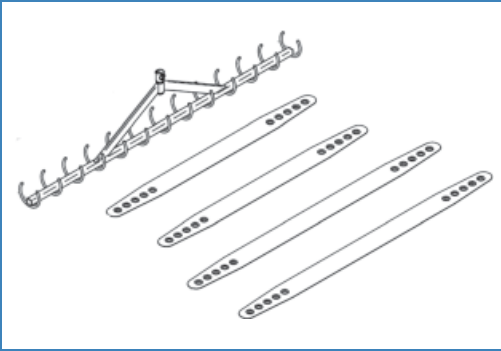

# PRODUCT	DESCRIPTION
#700.05380	Morgue Carry Bar - Standard
#700.05385	Morgue Carry Bar - Bariatric

FEATURES	
Machine washable	Easy to clean and care for.
Safe working load	272 kg / 600 lb / 42.86 st
Multiple positioning points	Both support bar and body bands have multiple positioning points to ensure a secure transfer
Stainless steel support bar	Frame is rust resistant so it can be submerged in water

TECHNICAL SPECIFICATIONS	
Conforms to ISO 10535 & Marked CE	
*Conditional to normal use and maintenance according to appropriate labels, the sling must be used only with the appropriate BHM Medical Inc. lifting devices.	

Morgue Transfer Device

MORGUE TRANSFER DEVICE				
# PRODUCT	DESCRIPTION	INCLUDED BANDS		
			CM	IN
#700.05380	Morgue Carry Bar - Standard	2 bands	119	47
	Capacity 136 kg - 300 lb max.	2 bands	145	57
#700.05385	Morgue Carry Bar - Bariatric	2 bands	119	47
	Capacity 136 kg - 300 lb to 272 kg - 600 lb max.	2 bands	183	72
# PRODUCT	DESCRIPTION	REPLACEMENT KIT		
			CM	IN
#700.05390	Band kit - Standard	2 bands	119	47
		2 bands	145	57
#700.05395	Band kit - Bariatric	2 bands	119	47
		2 bands	183	72

Refer to Sling Operating & Product Care Instructions Guide for complete application details.

INSTALLATION & APPLICATION METHOD

